

# FLAME DETECTOR RELAY FOR BURNER

PRODUCT: CHM-P-□-□1-R□

TECHNICAL SHEET 1/8

☎ Customer Service: 55 11 3019-1616

For more details, see technical bulletin

## ● APPLICATION

CHM-P is a flame detector relay, recommended to industrial or commercial burner, with cycle of **non-continuous use** (burner on/off within a period shorter than 24 hours).

**This product complies with the requirements of Norm NBR 12313 issued by ABNT – revision: Sept. 2000.**

It may be used in burners of gas, liquid or solid fuels, depending on the selected sensor. The options are:

⇒ **CHM-P- I** – Input for flame ionization sensor, when using gas as fuel in burners operating with this type of sensor. See sensor electrodes, SEL-HT or SEL-HT-E line (electrode mounted according to the client's drawing or sample).

⇒ **CHM-P- F** – Input for flame flicker infrared sensor.

Flame detector when using gas, oil or any other fuel that causes flame with light emission with the characteristics mentioned above.

See sensor information, SEL-SV-F line.

⇒ **CHM-P- U** – Input for ultraviolet radiation sensor, when using gas, light oils or any other fuel that causes flame with ultraviolet ray emission. See sensor of SEL-SV-U line.

⇒ **CHM-P- L** – Input for photosensor with cadmium sulphide resistance – visible radiation, when using heavy oils or any other fuel that causes flame with yellow light emission, applied in dark combustion chamber. See sensors of SEL-SV-L line.

⇒ **CHM-P- X** – With input for flame detection signal transmitter. With the use of transmitter ACS-TX-□-K5, it is possible to install flame sensor **I, F, L** or **U** (**without** auto fault diagnosis), **up to 500 meters** from the controller (relay or programmer). It is equipped with a circuit that enables to adjust the sensor sensitivity of the monitored flame, allowing the detection of adjacent flames and other possible emissions present in the walls of the combustion chamber. See the specifications of the flame detection signal transmitter ACS-TX-□-K5.



SELCON SISTEMAS ELETRÔNICOS DE CONTROLE LTDA.  
CNPJ 56.935.877/0001-29  
R. Américo Samarone, 502 • 04284-000 • Moinho Velho •  
São Paulo • SP • Tel./Fax: (55 11) 3019-1616  
<http://www.selcon.com.br>

Selcon Ltda. reserves the right to change this technical sheet when required. – Dec/2010

**Representative or Distributor:**

# FLAME DETECTOR RELAY FOR BURNER

PRODUCT: CHM-P-□-□1-R□

TECHNICAL SHEET 2/8

☎ Customer Service: 55 11 3019-1616

For more details, see technical bulletin

## ● TECHNICAL DATA

- ⇒ Power supply: 115 or 220 VAC; +10/-15%; 50/60 Hz
- ⇒ Power consumption: 3 VA
- ⇒ Internal fuse: 100 mA, retarded action.
- ⇒ **External fuse: Use a fuse to protect the output circuits, relays K1 and K2, according to the load planned in the project, respecting the limits of this specification.**
- ⇒ Protection against voltage surges
- ⇒ Flame sensor input: ionization, ultraviolet, visible light, infrared sensors (see ordering information)
- ⇒ Minimum flame current (uA-dc):  
I → 2 / U → 200 / L → 500 / F → 2,000 / X → 9,000

**NOTE: The flame sensor cable should be installed separately from the other cables of the burner command assembly. The best cable type recommended for this purpose is that used in ignition.**

- ⇒ Protection against faults caused by short-circuit in the mass ionization sensor
- ⇒ Anticipated flame or false signal of flame before the ignition start (outside the relay, via interlocking – under the client's responsibility).
- ⇒ Confirmation time to flame input: < 1 sec.
- ⇒ Response time to flame fault: < 4 sec.
- ⇒ Front indicators: equipment in operation (**Vm**) – burning flame (**Vd**)
- ⇒ Option: Internal relay K2 with timed activation (5 sec.) in CHM-P energization
- ⇒ Electrical connections: through 10 terminals on the box front panel
- ⇒ Max. current of outputs (in 250 VAC<sub>max</sub>): 2 A resistive
- ⇒ Electrical life expectancy of output contacts: > 100,000 operations
- ⇒ Mechanical life expectancy of output contacts: > 10,000,000 operations
- ⇒ Operating temperature: 0 to 60°C
- ⇒ Ambient temperature for storage: -5°C to +65°C
- ⇒ Max. relative air humidity in operation: 90% (40 ± 2°C) – NBR 5291
- ⇒ Protection degree in relation to the environment: IP 40
- ⇒ Housing: Plastic gray housing
- ⇒ Assembly: On flat sheltered surface
- ⇒ Attachment: DIN Rail 35 mm or screws on the housing base
- ⇒ Weight: 312 grams
- ⇒ Warranty: 12 months (**see warranty terms**)



SELCON SISTEMAS ELETRÔNICOS DE CONTROLE LTDA.  
CNPJ 56.935.877/0001-29  
R. Américo Samarone, 502 • 04284-000 • Moinho Velho •  
São Paulo • SP • Tel./Fax: (55 11) 3019-1616  
<http://www.selcon.com.br>

Selcon Ltda. reserves the right to change this technical sheet when required. – Dec/2010

**Representative or Distributor:**

--

# FLAME DETECTOR RELAY FOR BURNER

PRODUCT: CHM-P-□-□1-R□

TECHNICAL SHEET 3/8

Customer Service: 55 11 3019-1616

For more details, see technical bulletin

## ● ASSEMBLY DRAWING

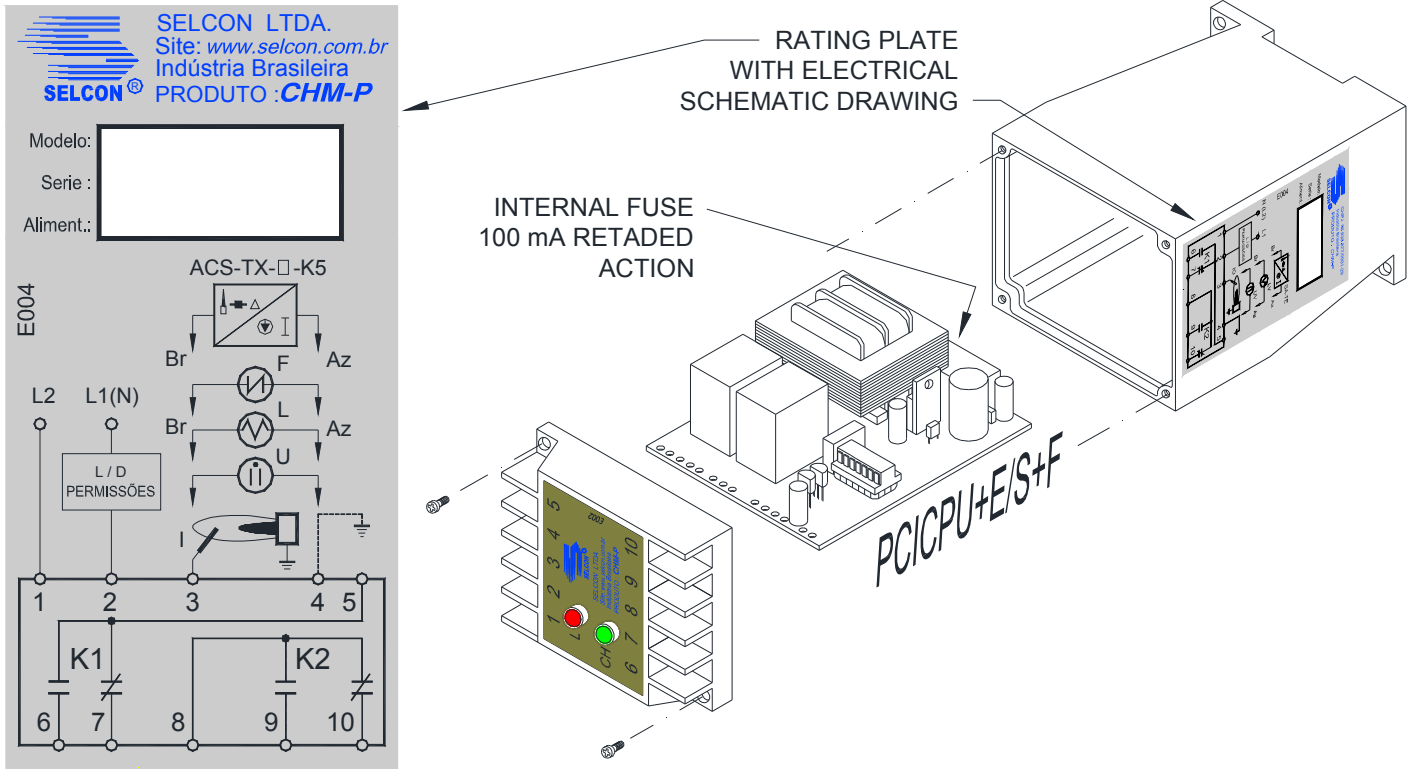

FIG 1

## ● DIMENSIONS (mm)

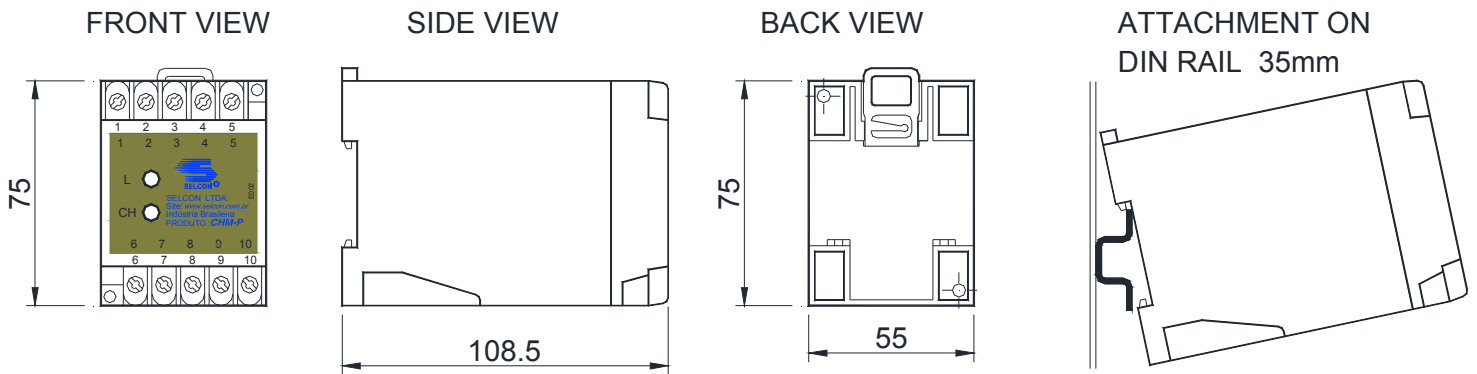

FIG 2



SELCON SISTEMAS ELETRÔNICOS DE CONTROLE LTDA.  
CNPJ 56.935.877/0001-29  
R. Américo Samarone, 502 • 04284-000 • Moinho Velho •  
São Paulo • SP • Tel./Fax: (55 11) 3019-1616  
<http://www.selcon.com.br>

Selcon Ltda. reserves the right to change this technical sheet when required. – Dec/2010

Representative or Distributor:

# FLAME DETECTOR RELAY FOR BURNER

PRODUCT: CHM-P-□-□1-R□

TECHNICAL SHEET 4/8

☎ Customer Service: 55 11 3019-1616

For more details, see technical bulletin

● **GENERAL SCHEMATIC DRAWING OF ELECTRICAL CONNECTIONS**

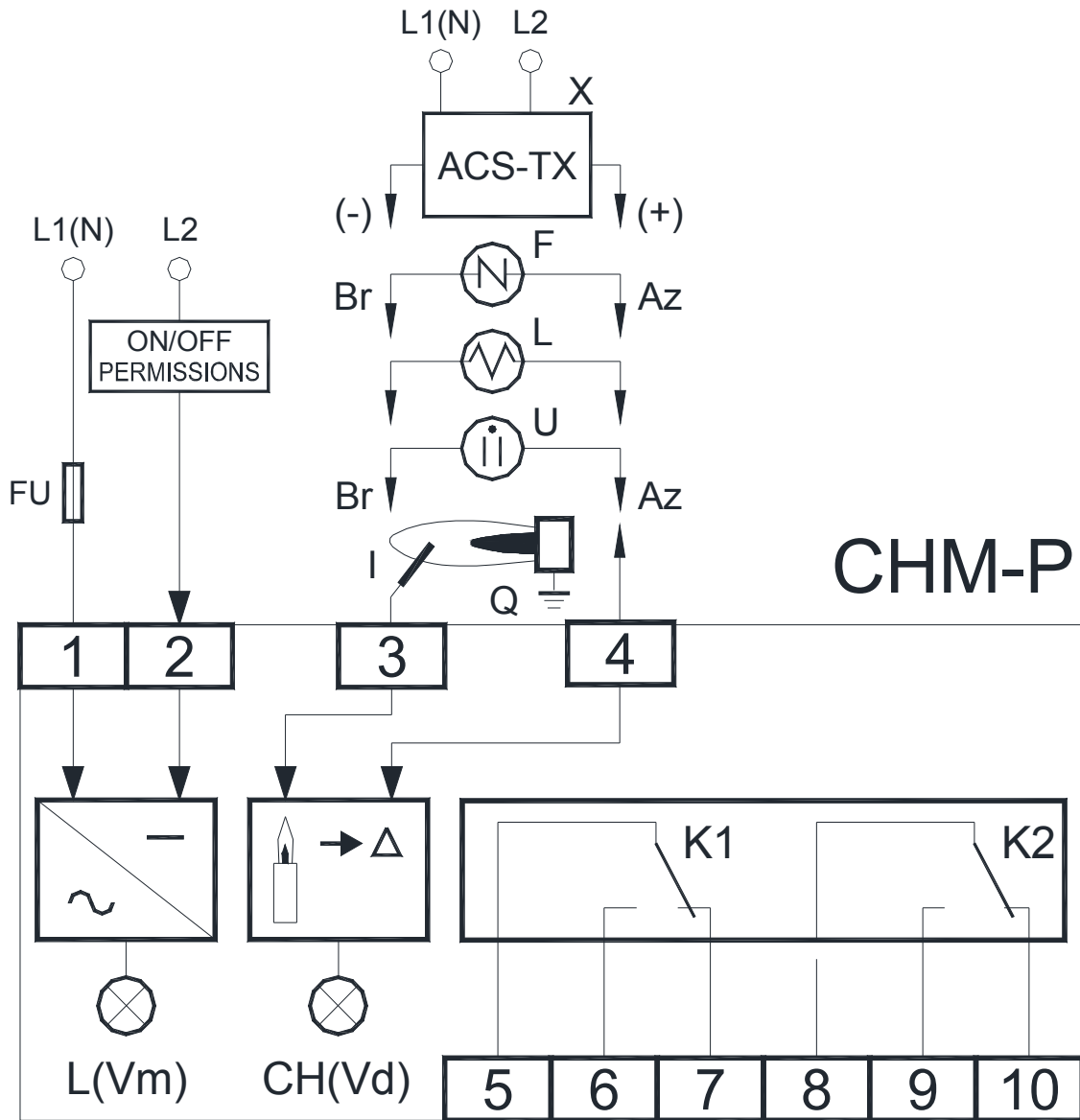

FIG 3

● **OPERATION**

When energized, relay CHM-P starts the flame monitoring. The maintenance of activated internal relays K1 and K2 will be dependent on the flame presence or a false signal simulating the flame presence. Internal relay K2 may be activated with CHM-P energization, for max. 5 seconds, regardless of the flame situation, by changing the position of internal jumper **J1**. Provided that the flame presence is confirmed, and while it persists, relays K2 and K1 will remain activated.

**IMPORTANT:** The burner safety lock and the flame confirmation before the start or the false signal simulating flame is the user's responsibility. Relay CHM-P just indicates the flame presence or absence.



SELCON SISTEMAS ELETRÔNICOS DE CONTROLE LTDA.  
 CNPJ 56.935.877/0001-29  
 R. Américo Samarone, 502 • 04284-000 • Moinho Velho •  
 São Paulo • SP • Tel./Fax: (55 11) 3019-1616  
<http://www.selcon.com.br>

*Representative or Distributor:*

*Selcon Ltda. reserves the right to change this technical sheet when required. – Dec/2010*

# FLAME DETECTOR RELAY FOR BURNER

PRODUCT: CHM-P-□-□1-R□

TECHNICAL SHEET 5/8

Customer Service: 55 11 3019-1616

For more details, see technical bulletin

## ELECTRICAL CONNECTIONS OF FLAME SENSORS

- 1- Input for ionization sensor electrode, SEL-HT-I or SEL-HT-E line (electrode mounted according to the client's drawing or sample):

WHEN MEASURING WITH MICROAMMETER, DO NOT LET THE LIVE ENDS TOUCH ANYTHING.

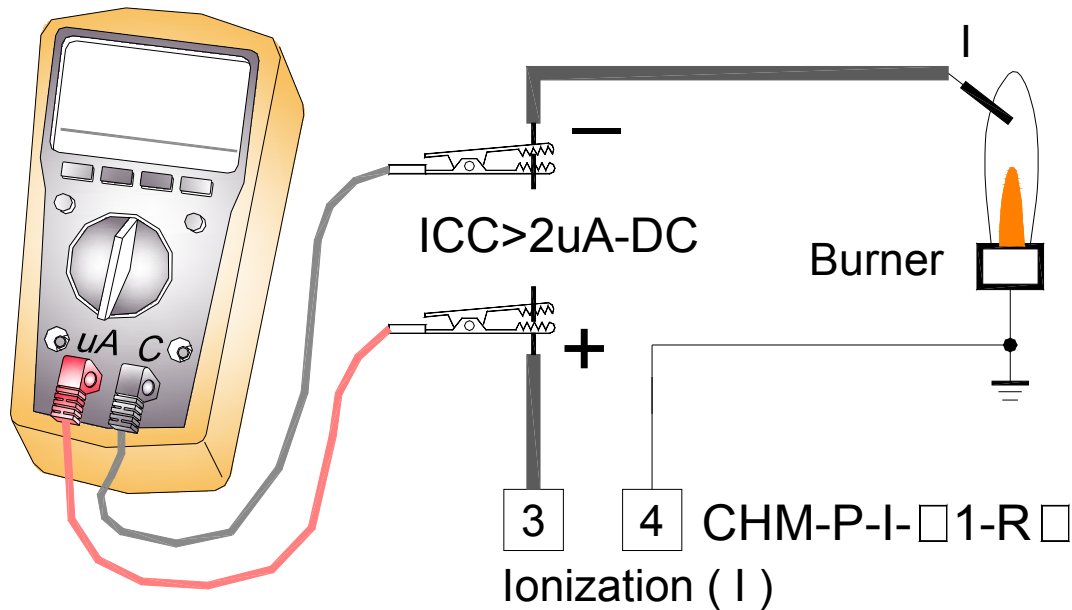

FIG 4

- 2 – Input for infrared radiation sensor (Flicker), SEL-SV-F line:

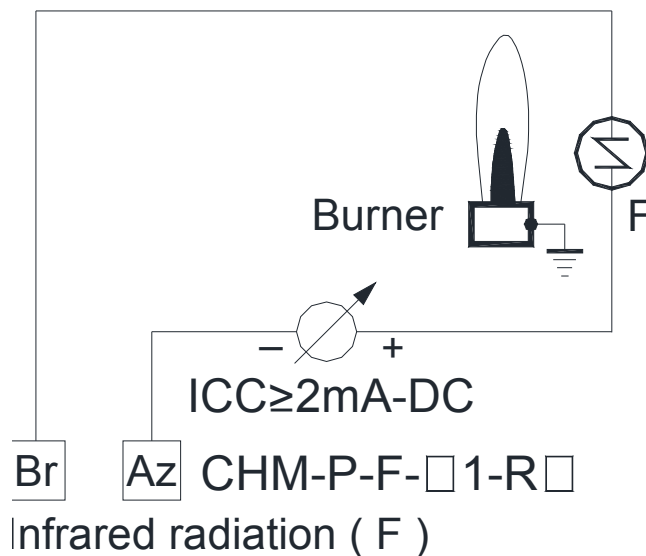

FIG 5



SELCON SISTEMAS ELETRÔNICOS DE CONTROLE LTDA.  
 CNPJ 56.935.877/0001-29  
 R. Américo Samarone, 502 • 04284-000 • Moinho Velho •  
 São Paulo • SP • Tel./Fax: (55 11) 3019-1616  
<http://www.selcon.com.br>

Selcon Ltda. reserves the right to change this technical sheet when required. – Dec/2010

Representative or Distributor:

# FLAME DETECTOR RELAY FOR BURNER

PRODUCT: CHM-P-□-□1-R□

TECHNICAL SHEET 6/8

☎ Customer Service: 55 11 3019-1616

For more details, see technical bulletin

3 – Input for ultraviolet radiation sensor, SEL-SV-U line:

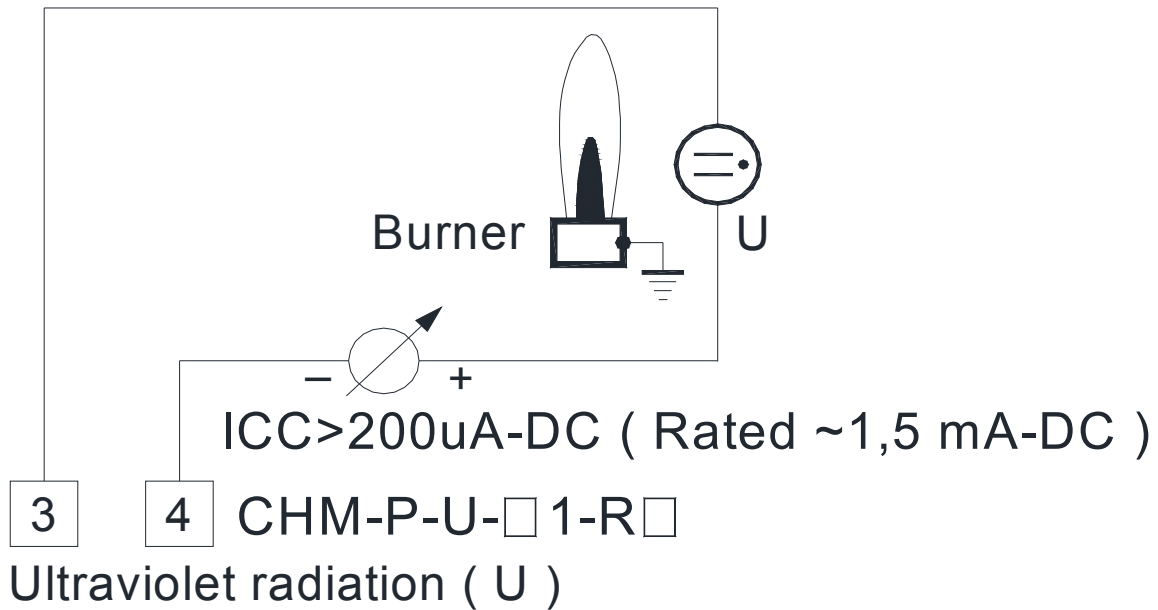

FIG 6

4 – Input for visible radiation sensor, SEL-SV-L line:

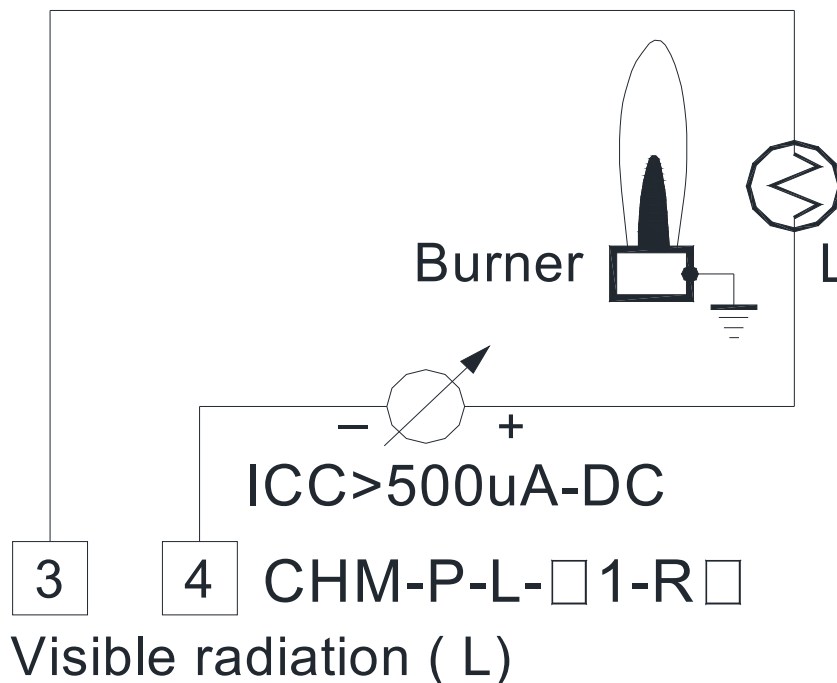

FIG 7



SELCON SISTEMAS ELETRÔNICOS DE CONTROLE LTDA.  
CNPJ 56.935.877/0001-29  
R. Américo Samarone, 502 • 04284-000 • Moinho Velho •  
São Paulo • SP • Tel./Fax: (55 11) 3019-1616  
<http://www.selcon.com.br>

Selcon Ltda. reserves the right to change this technical sheet when required. – Dec/2010

Representative or Distributor:

# FLAME DETECTOR RELAY FOR BURNER

**PRODUCT: CHM-P-□-□1-R□**

**TECHNICAL SHEET 7/8**

**Customer Service: 55 11 3019-1616**

For more details, see technical bulletin

## 5 – Input for flame detection signal transmitter, ACS-TX-□-K5 model:

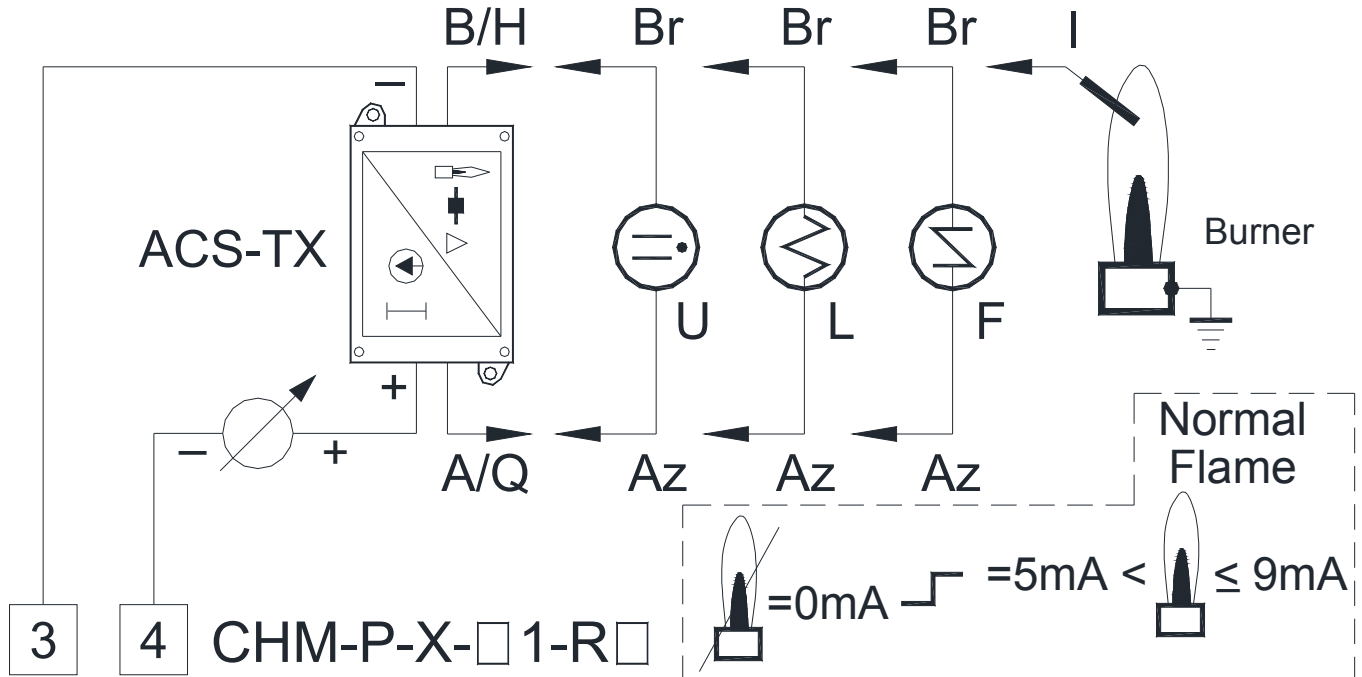

**FIG 8**



**SELCON SISTEMAS ELETRÔNICOS DE CONTROLE LTDA.**  
 CNPJ 56.935.877/0001-29  
 R. Américo Samarone, 502 • 04284-000 • Moinho Velho •  
 São Paulo • SP • Tel./Fax: (55 11) 3019-1616  
<http://www.selcon.com.br>

*Selcon Ltda. reserves the right to change this technical sheet when required. – Dec/2010*

**Representative or Distributor:**

# FLAME DETECTOR RELAY FOR BURNER

**PRODUCT: CHM-P-□□1-R□**

**TECHNICAL SHEET 8/8**

☎ Customer Service: 55 11 3019-1616

For more details, see technical bulletin

● **ORDERING INFORMATION - CHM-P-□□1-R□**

CHM-P	SENSOR	POWER SUPPLY		R - RESPONSE TO FLAME FAULT
	<b>I</b> IONIZATION  <b>F</b> INFRARED (FLICKER)  <b>U</b> ULTRAVIOLET  <b>L</b> VISIBLE LIGHT  <b>X</b> TRANSMITTER	<b>VOLTAGE</b>  <b>(d1)</b>  d1 = 1 => 115Vac  OR  d1 = 2 => 220Vac	<b>FREQUENCY</b>  d2 = 1  =>50/60 Hz	<b>(d3)</b>  d3 = 1 => 1 sec.  OR  d3 = 2 => 3 sec.

**Note:** The sensor and other accessories should be specified separately, according to their tables with corresponding codes.

● **WARNING:**

⇒ Use the sensor only with programmers and/or detector relays made by Selcon.

● **OTHER PRODUCTS AND ACCESSORIES:**

- ⇒ Flame relays: CHM-SE, CHM-P, CHM-M, CHM-M-IIIme (with base) and CHM-F
- ⇒ Automatic valve proving control: CHM -T
- ⇒ Ignition and flame monitoring programmers: PRG-SE, PRG-E, PRG-Ie,
- ⇒ PRG-Ie-IIIme (with base), PRG-I, PRG-M and PRG-M-IIIme (with base)
- ⇒ Flame optical sensors: SEL- SV
- ⇒ Ionization flame sensors and ignition electrodes: SEL- HT (standard) and SEL- HT-E (sensors and electrodes mounted under drawing or customer sample- special);
- ⇒ Flame signal transmitter: ACS -TX (up to 500 meters between sensor and relay or programmer)
- ⇒ Flame signal converter for 4 -20 mA: ACS - CV
- ⇒ Ignition transformers: ACS -TE (for supply in VAC or VCC)
- ⇒ Timed ignition panel: ACS - IT
- ⇒ Portable ignitor: ACS - IP (operates on batteries)
- ⇒ Ignition panel (operates on batteries): ACS-PN-E
- ⇒ Ignition panel and flame monitoring: PRG-Ie/O3
- ⇒ Cables: ACS - CB (ignition / sensing / communication / control)
- ⇒ Touch-sensitive connector and protector for ignition cable: ACS-CP
- ⇒ Articulate connection ACS-CN
- ⇒ Ignition and monitoring panel: ACS-PN (on request)
- ⇒ Reform service for pilot burners: on request
- ⇒ **PRODUCTION DATA SUPERVISOR LINE**



SELCON SISTEMAS ELETRÔNICOS DE CONTROLE LTDA.  
 CNPJ 56.935.877/0001-29  
 R. Américo Samarone, 502 • 04284-000 • Moinho Velho •  
 São Paulo • SP • Tel./Fax: (55 11) 3019-1616  
<http://www.selcon.com.br>

*Representative or Distributor:*

Selcon Ltda. reserves the right to change this technical sheet when required. – Dec/2010